



*Retractable Screens for*  
LARGE OPENINGS | DOORS | WINDOWS

 **PHANTOM**  
SCREENS  
*experience the moment*

*table of contents*

---

**INTRODUCTION 01**

**LARGE OPENINGS 02**

- EXECUTIVE 04
- Applications 05
- Customization 06
- Controls and Automation 08
- Specifications 10

**DOORS 12**

- LEGACY 14
  - Applications 15
  - Customization 16
  - Specifications 17
- PROFESSIONAL 18
- Applications 19
  - Customization 20
  - Specifications 21

**WINDOWS 22**

- SERENE 24
  - Applications 25
  - Customization 26
  - Specifications 27
- PRESTIGE 28
- Applications 29
  - Customization 30
  - Specifications 31



*experience the moment*

HIDES  
SIMPLY

OPENS  
SMOOTHLY

CLOSES  
SECURELY

*Phantom provides  
retractable screens for*

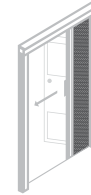

**DOORS**

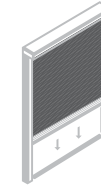

**WINDOWS**

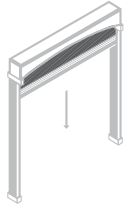

**LARGE  
OPENINGS**

*Since 1992, Phantom Screens has expertly manufactured and professionally installed industry leading retractable screens in North America.*

*Known for superior quality and elegant design, Phantom Screens enables homeowners to experience a new level of comfort, style and versatility.*

---

**BENEFITS**

- Allows full ventilation
- Maintains décor and view
- Expands your living space
- Protects against UV rays and insects
- Integrates seamlessly into your home
- Professionally installed
- Backed by a limited lifetime warranty





---

# LARGE OPENINGS

Imagine having motorized screens that disappear at the touch of a button. Or being able to screen a folding glass wall. Imagine being able to move seamlessly between indoor and outdoor spaces – without the intense glare of the sun or annoying mosquitoes. You can, thanks to Phantom's retractable screens for large openings. With Phantom Screens, outdoor living is an insect-free pleasure and summer entertaining at home is easy!

— PHANTOM —  
*Executive*<sup>™</sup>  
Retractable Screens<sup>™</sup>

*The motorized retractable  
screen for large openings*

---

**FEATURES**

- Retracts vertically
- Weighted slidebar
- Various mesh and color options
- Optional sun and wind sensors
- In-wall or hand-held remote controls

---

**BENEFITS**

- Solar shading
- Insect protection
- Fresh air ventilation
- Lower air conditioning costs

---

**INSTALLATION OPTIONS**

- Surface mount
- Recessed into walls, columns  
and ceiling cavities



# Applications

Executive screens are custom made and professionally installed to fit a wide variety of large openings.

## ADDITIONAL APPLICATIONS

Large picture windows

Folding walls

Lift and slide door systems

**Patios**



**Verandas/Lanais**



**Porches**



**Balconies**



# Customization

## FINISHES

### Designer Colors

Choose from one of nine designer colors or decorative wood grain finishes.



CLASSIC  
WHITE

SLIVERED  
ALMOND

SANDAL  
WOOD

DRIFTWOOD  
BEIGE

HARTFORD  
GREEN

RIDEAU  
BROWN

COASTAL  
GREY

MINERAL  
BRONZE

PHANTOM  
BLACK

### Wood Grain



LIGHT  
KNOTTY PINE

LIGHT FIR

LIGHT OAK

DARK  
KNOTTY PINE

DARK OAK

LIGHT  
CHERRY

DARK  
ACACIA

LIGHT ASH

LIGHT  
CEDAR



DARK FIR



DARK  
CHERRY



DARK ASH



DARK  
CEDAR



DARK  
WALNUT



MAHOGANY

### Custom Color

Phantom Screens also offers a wide range of color options including a custom color matching program to blend our screens with any color scheme.

\* Please note that the appearance of the colors illustrated will differ from the actual coated samples or finished articles.

## MESH

All mesh options seal out insects, reduce heat and glare as well as prevent fading of furnishings. There are 30 different mesh options to choose from. Speak with your Phantom Screens Representative to learn more.



**STANDARD**  
Reduces up to 55% of UV rays



**SOLAR**  
Blocks up to 75% of UV rays



**PREMIUM SOLAR**  
Blocks up to 80% of UV rays,  
provides significant shade and  
is available in multiple colors

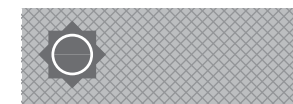

**PRIVACY**  
Blocks up to 100% of UV rays,  
available in multiple colors



---

## ARCHITECTURAL INTEGRATION

Customized to each building project, Executive screens merge perfectly with the décor to maintain the integrity of your design. These retractable screens can be recessed from view or mounted on existing structures. Executive screens can be integrated into every type of architectural style including wood, brick, stucco, natural stone and concrete.

### Recessed in Roman archways



### Natural stone and wood



### Recessed in columns



### Stucco, brick and concrete



# Controls and Automation

Phantom Screens has partnered with Somfy to provide a wide range of remote controls and sensor controls for Executive motorized retractable screens.



In addition Executive screens can be integrated into most home automation systems including Lutron and Crestron.

## Hand-held Remotes

All Somfy's Telis hand-held remotes feature Radio Technology Somfy® (RTS) providing push button control. The Telis RTS collection is available in single or multiple channel versions. Each channel can be used to operate one screen or a group of screens at the same time from one remote control.



**TELIS 16 CHANNEL**

## Wireless Switches

Somfy's DecoFlex WireFree™ switches are completely wireless, battery powered and available in four colors - white, ivory, black and almond.



**WHITE**

## Sun and Wind Sensors



### SUNIS SUN SENSOR

A wireless sun sensor, powered with an integrated solar cell, to automatically adjust motorized screens based on the sun's intensity.



### EOLIS RTS SENSOR

A wind sensor that can be used to automatically retract your screens into their protective housings in stormy conditions.



### SOLIRIS RTS SENSOR

A combined sun and wind sensor that automatically adjusts motorized screens depending on sun and wind intensity.



# Specifications

Executive screens are custom fit and professionally installed for single openings as large as 25 feet wide by 16 feet tall. Refer to the chart below for maximum and minimum size dimensions.

STYLE	WIDTH	HEIGHT
4" housing	26" to 120"	Max 96"
5-1/2" housing	34" to 240"	Max 132"
7-1/8" housing	34" to 300"	Max 192"

FOR ILLUSTRATIVE PURPOSES ONLY  
NOT DRAWN TO SCALE

All components are color matched  
except mesh and bottom seal.

## SURFACE MOUNT

### EXECUTIVE DESIGN SPECIFICATIONS SYSTEM WITH STANDARD SIDE TRACK (external assembled view)

#### PARTS SPECS

- A** Housing assembly (5-1/2" W x 5-1/2" H or 7-1/8" W x 7-1/8" H)
- B** 8 x 1" corrosion resistant fastener (color matched) 3 fasteners per end cap
- C** PVC coated fiberglass mesh or other (see mesh specifications)
- D** Standard side track complete with cover (1-3/4" W x 1-7/32" D)
- E** Slidebar complete with probe assembly
- F** Bottom seal - 4" shown (other options available)
- G** Mounting surfaces

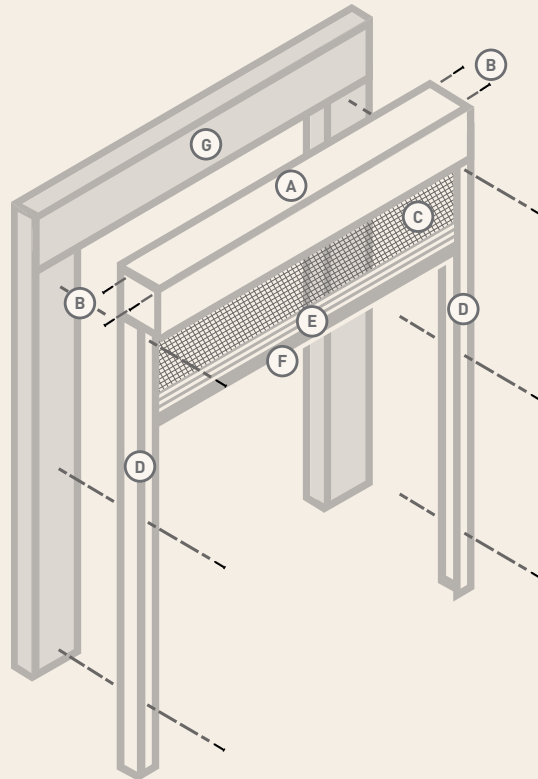

Cross sectional view  
of the standard side track

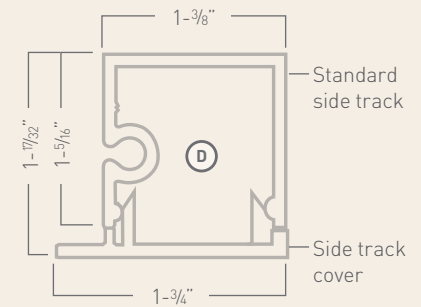

Cross sectional view  
of the standard slidebar  
and 4" bottom seal

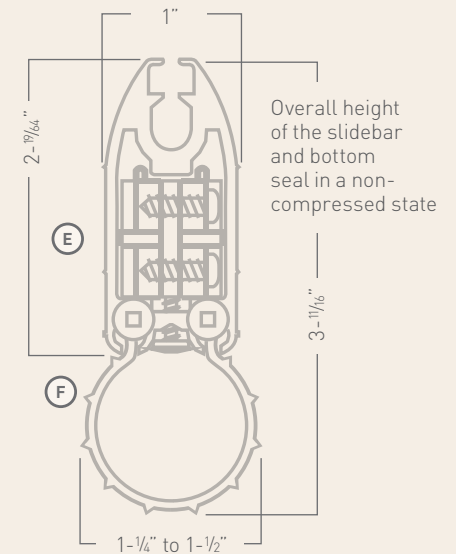

## RECESSED MOUNT

### EXECUTIVE DESIGN SPECIFICATIONS SYSTEM WITH RECESSED SIDE TRACK

(external assembled view)

#### PARTS SPECS

- A** Roller assembly (4" or 5") complete with inserts (left and right)
- B** PVC coated fiberglass mesh or other (see mesh specifications)
- C** Recessed side track assembly (1-3/8" W x 2-7/64" D)
- D** #8 or #10 corrosion resistant fastener. Type and length of screws may vary depending on type of mounting surface (minimum of 3 per side track and roller mounting angle)
- E** Slidebar complete with probe assembly
- F** Bottom seal - 4" shown (other options available)
- G** Roller mounting bracket (2" x 5-1/2" x 1/4" x 3-1/8" W)

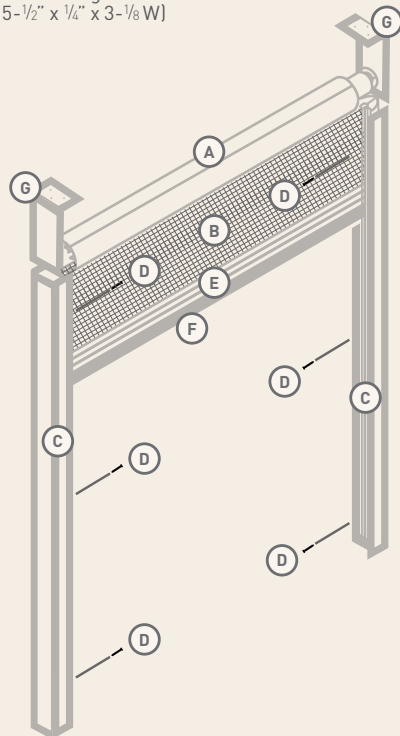

### Cross sectional view of the fully assembled recessed side track

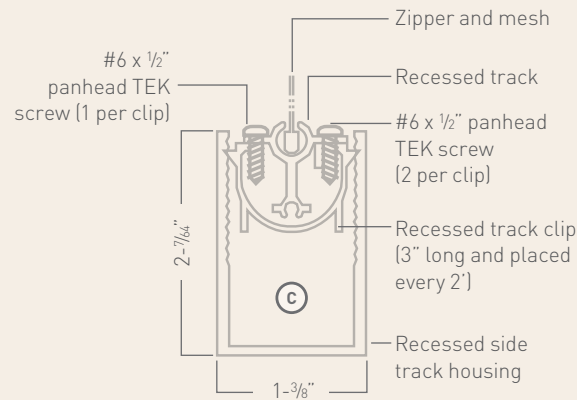

### Roller mounting angle for 4" and 5" rollers

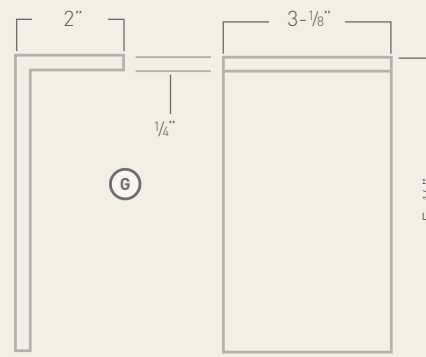

### Cross sectional view of the slidebar and 4" bottom seal

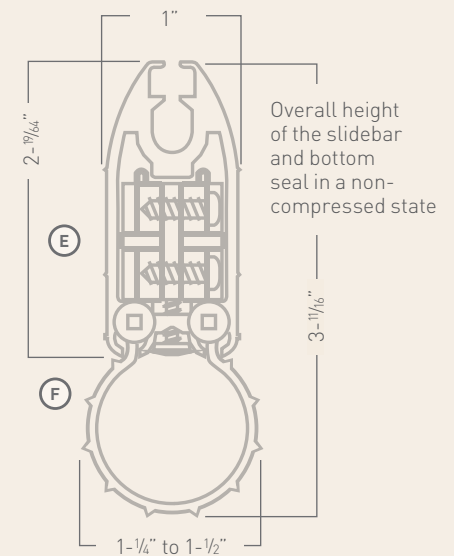





---

# DOORS

There's nothing like being able to leave your door wide open to enjoy the breeze, especially towards the end of a hot summer day. Retractable door screens by Phantom are insect screens which disappear out of sight into a discreet housing, giving you fresh air without the bugs — and won't spoil the look of your home. They come in a wide variety of colors, sizes and mesh types, perfectly matching with your décor.

— PHANTOM —  
*Legacy*<sup>™</sup>  
Retractable Screens<sup>™</sup>

*The retractable screen door with an integrated Latch and Release handle*

---

**FEATURES**

- Latch and Release handle
- Fits most door types
- Built-in lubricant
- Glides smoothly along tracks
- Various mesh and color options

---

**BENEFITS**

- Insect protection
- Fresh air ventilation
- Retracts out of sight
- Easy operation with secure closure

---

**INSTALLATION OPTIONS**

- In-jamb mount
- Surface mount





# Applications

Legacy screens are custom made, professionally installed and designed to fit a variety of doorways.

**Legacy's Latch and Release handle** automatically latches the screen in the closed position to prevent it from opening in breezy conditions. It is easy to use and quiet to operate.



**Double-French doors**



**Sliding patio doors**



**Single out-swing/in-swing doors**



**Oversized doors**



# Customization

## FINISHES

### Designer Colors

Choose from one of ten designer colors or decorative wood grain finishes.



CLASSIC WHITE    CALICO LINEN    SLIVERED ALMOND    SANDAL WOOD    DRIFTWOOD BEIGE    HARTFORD GREEN    RIDEAU BROWN    COASTAL GREY    MINERAL BRONZE    PHANTOM BLACK

### Wood Grain



LIGHT KNOTTY PINE    LIGHT FIR    LIGHT OAK    DARK KNOTTY PINE    DARK OAK    LIGHT CHERRY    DARK ACACIA    LIGHT ASH    LIGHT CEDAR



DARK FIR    DARK CHERRY    DARK ASH    DARK CEDAR    DARK WALNUT    MAHOGANY

### Custom Color

Phantom Screens also offers a wide range of color options including a custom color matching program to blend our screens with any color scheme.

\* Please note that the appearance of the colors illustrated will differ from the actual coated samples or finished articles.

## MESH

All mesh options seal insects out and provide some level of heat, glare and UV reduction.

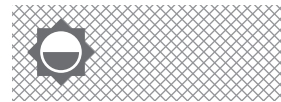

**STANDARD**  
Reduces up to 55% of UV rays

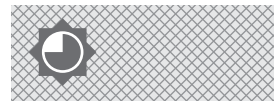

**SOLAR**  
Blocks up to 75% of UV rays

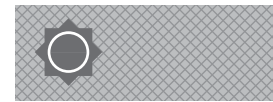

**PRIVACY**  
Blocks up to 90% of UV rays, available in multiple colors

# Specifications

Legacy screens are custom made and professionally installed for all door types. Maximum sizes are determined by the height and width ratios detailed in the chart below.

	WIDTH	HEIGHT
SINGLE UNIT	Max 48"	78" to 100"
	Max 36"	100 1/8" to 120"
DOUBLE UNIT	Max 96"	78" to 100"
	Max 72"	100 1/8" to 120"

FOR ILLUSTRATIVE PURPOSES ONLY  
NOT DRAWN TO SCALE

All components are color matched except mesh.

## SURFACE MOUNT

### LEGACY DESIGN SPECIFICATIONS (external assembled view)

#### PARTS SPECS

- A** Aluminum housing complete with nylon end caps 1-7/8" W x 2-43/64" D
- B** Aluminum track
- C** #8 x 2-1/2" flathead screw
- D** #6 x 3/4" panhead screw
- E** Screws position on mounting surface
- F** Bumpons - 1/2" Ø x 1/4" H
- G** Outside nylon Latch and Release handle
- H** Inside nylon Latch and Release handle
- I** Aluminum sidebar
- J** #6 x 5/8" panhead TEK screw
- K** Nickel plated zinc lever components
- L** # 6/32 x 1-5/8" S.S. bolt
- M** # 6/32 locknut S.S.
- N** Handle screw caps (2 per handle)
- O** Track catch

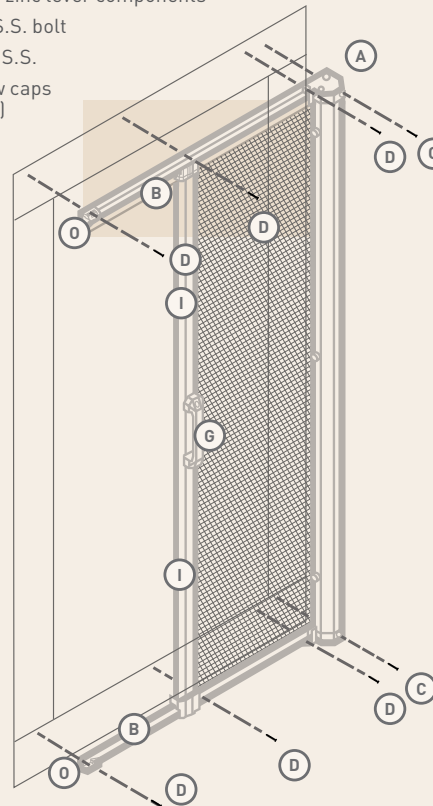

Detail of track position in relation to the housing and housing end cap  
Head view

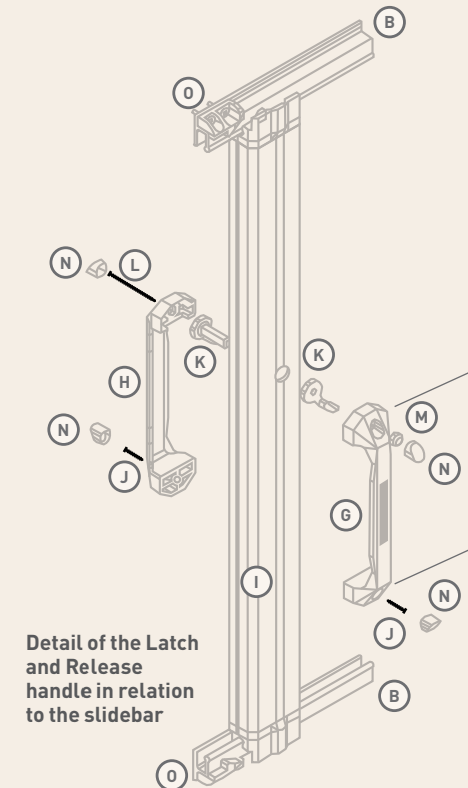
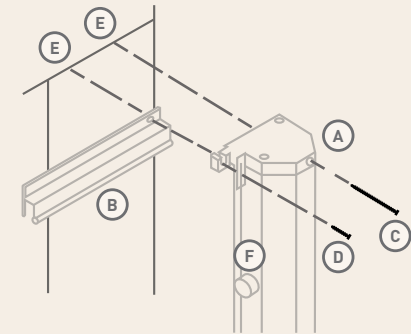

Detail of the Latch and Release handle in relation to the sidebar

PHANTOM  
*Professional*<sup>™</sup>  
SERIES  
Retractable Screens<sup>™</sup>

*The retractable screen door  
with a magnet latching system*

---

**FEATURES**

- Magnet latch
- Fits most door types
- Glides smoothly along tracks
- Various mesh and color options

---

**BENEFITS**

- Insect protection
- Fresh air ventilation
- Retracts out of sight
- Easy operation with secure closure
- Simple “break away” on impact

---

**INSTALLATION OPTIONS**

- In-jamb mount
- Surface mount



# Applications

Professional screens are custom made, professionally installed and designed to fit a variety of doorways.

## Professional's Magnet Latch

The Professional screen is held in place with magnets and “breaks away” on impact to prevent damage to the screen mesh.



**Double-French doors**



**Sliding patio doors**



**Single out-swing/in-swing doors**



**Oversized doors**



# Customization

## FINISHES

### Designer Colors

Choose from one of ten designer colors or decorative wood grain finishes.



CLASSIC WHITE    CALICO LINEN    SLIVERED ALMOND    SANDAL WOOD    DRIFTWOOD BEIGE    HARTFORD GREEN    RIDEAU BROWN    COASTAL GREY    MINERAL BRONZE    PHANTOM BLACK

### Wood Grain



LIGHT KNOTTY PINE    LIGHT FIR    LIGHT OAK    DARK KNOTTY PINE    DARK OAK    LIGHT CHERRY    DARK ACACIA    LIGHT ASH    LIGHT CEDAR



DARK FIR    DARK CHERRY    DARK ASH    DARK CEDAR    DARK WALNUT    MAHOGANY

### Custom Color

Phantom Screens also offers a wide range of color options including a custom color matching program to blend our screens with any color scheme.

\* Please note that the appearance of the colors illustrated will differ from the actual coated samples or finished articles.

## MESH

All mesh options seal out insects, reduce heat and glare as well as prevent fading of furnishings.



**STANDARD**  
Reduces up to 55% of UV rays



**SOLAR**  
Blocks up to 75% of UV rays



**PRIVACY**  
Blocks up to 90% of UV rays,  
available in multiple colors

# Specifications

Professional screens are custom made and professionally installed for all door types. Maximum sizes are determined by the height and width ratios detailed in the chart below.

	WIDTH	HEIGHT
SINGLE UNIT	Max 48"	78" to 100"
	Max 36"	100 1/8" to 120"
DOUBLE UNIT	Max 96"	78" to 100"
	Max 72"	100 1/8" to 120"

FOR ILLUSTRATIVE PURPOSES ONLY  
NOT DRAWN TO SCALE

All components are color matched except mesh.

## SURFACE MOUNT

### PROFESSIONAL DESIGN SPECIFICATIONS (external assembled view)

#### PARTS SPECS

- A** Aluminum housing complete with nylon end caps 1-7/8" W x 2-49/64" D
- B** Aluminum track
- C** #8 x 2-1/2" flathead screw
- D** #6 x 3/4" panhead screw
- E** Screws position on mounting surface
- F** Bumpons - 1/2" Ø x 1/4" H
- G** Outside nylon handle
- H** Inside nylon handle
- I** Aluminum sidebar
- J** #6 x 5/8" panhead TEK screw
- K** Corrosion resistant steel magnet strike plate
- L** #6 x 3/4" (#5 head) flathead screw
- M** Nylon magnet housing
- N** Handle screw caps (2 per handle)

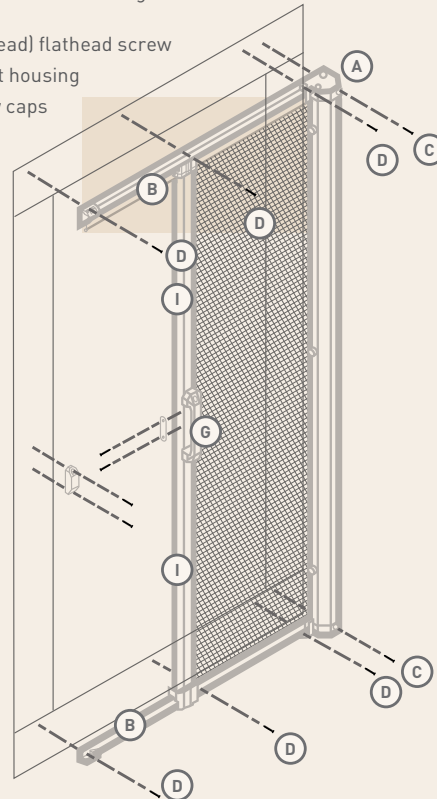

Detail of track position in relation to the housing and housing end cap  
Head view

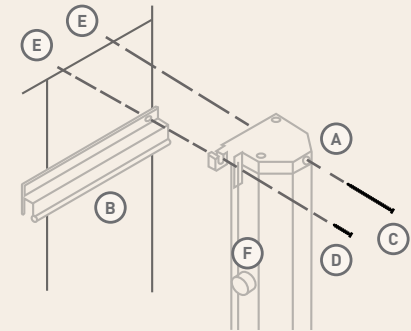

Detail of the Magnet Latch in relation to the sidebar

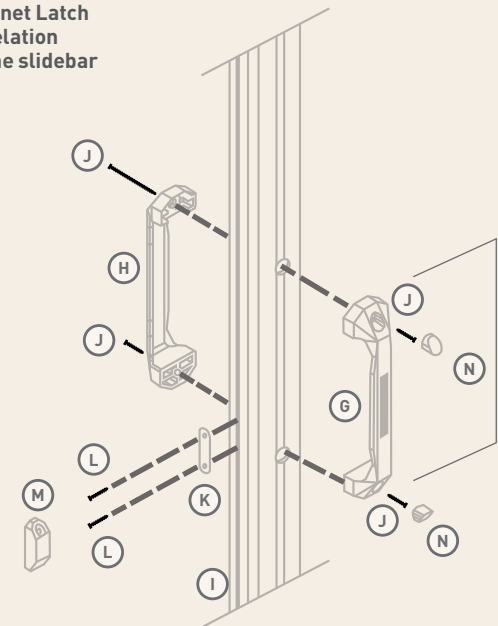







---

# WINDOWS

The trouble with traditional fixed window screens is that they're always there—compromising your view, making window cleaning difficult and detracting from the aesthetics of your home. With Phantom's retractable window screens you can enjoy insect-free ventilation and your view. They're available for all types and sizes of windows—even custom wood windows—and can be used for insect protection or solar shading. So when your home is basking in sunshine you can fling your windows wide open and welcome the breeze!



*The retractable screen  
for all window types*

---

**FEATURES**

- Built-in latch
- Mesh retention system
- Various mesh and color options
- Ergonomically designed handle

---

**BENEFITS**

- Solar shading
- Privacy
- Insect protection
- Fresh air ventilation
- Retracts out of sight
- Unobstructed views

---

**INSTALLATION OPTIONS**

- In-jamb mount
- Surface mount



# Applications

Serene screens are custom made and professionally installed to fit all window types.

## ADDITIONAL APPLICATIONS

- Sliding
- Tilt and turn

**Single-hung**



**Double-hung**



**Casement**



**Awning**



# Customization

## FINISHES

### Designer Colors

Choose from one of eight designer colors or decorative wood grain finishes.



CLASSIC WHITE    SLIVERED ALMOND    SANDAL WOOD    DRIFTWOOD BEIGE    HARTFORD GREEN    RIDEAU BROWN    COASTAL GREY    PHANTOM BLACK

### Wood Grain



LIGHT KNOTTY PINE    LIGHT FIR    LIGHT OAK    DARK KNOTTY PINE    DARK OAK    LIGHT CHERRY    DARK ACACIA    LIGHT ASH    LIGHT CEDAR



DARK FIR    DARK CHERRY    DARK ASH    DARK CEDAR    DARK WALNUT    MAHOGANY

### Custom Color

Phantom Screens also offers a wide range of color options including a custom color matching program to blend our screens with any color scheme.

\* Please note that the appearance of the colors illustrated will differ from the actual coated samples or finished articles.

## MESH

All mesh options seal out insects, reduce heat and glare as well as prevent fading of furnishings.

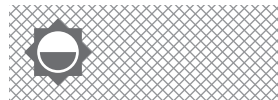

**STANDARD**  
Reduces up to 55% of UV rays



**SOLAR**  
Blocks up to 75% of UV rays



**PREMIUM SOLAR**  
Blocks up to 80% of UV rays, provides significant shade and is available in multiple colors

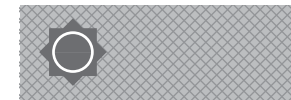

**PRIVACY**  
Blocks up to 100% of UV rays, available in multiple colors

# Specifications

Serene screens are custom made and professionally installed for virtually any window application. Maximum sizes are determined by the height and width ratios detailed in the chart below.

	WIDTH	HEIGHT
SERENE	13 1/2" to 84"	Max 90"

NOTE: Width/Height ratio limitations may apply. Your Phantom Screens Representative will confirm suitability based on site dimensions.

FOR ILLUSTRATIVE PURPOSES ONLY  
NOT DRAWN TO SCALE

All components are color matched except the mesh.

## SURFACE MOUNT

**SERENE DESIGN SPECIFICATIONS**  
(external assembled view)

### PARTS SPECS

- A** Aluminum track  
Standard version -  $57/64$ " W x  $1-3/8$ " H  
Narrow version -  $57/64$ " W x  $29/32$ " H
- B** Aluminum slidebar  $3/32$ " W x  $1-13/32$ " H
- C** Aluminum housing assembly  $2-19/64$ " W x  $2-7/64$ " H
- D** PVC coated fiberglass mesh
- E** Flathead screw #6 x  $3/4$ " (#5 head) - depending on mounting surface
- F** Track screw hole cover
- G** Track latch
- H** Mesh retention pile - inside full track length (both sides)
- I** Mounting surface

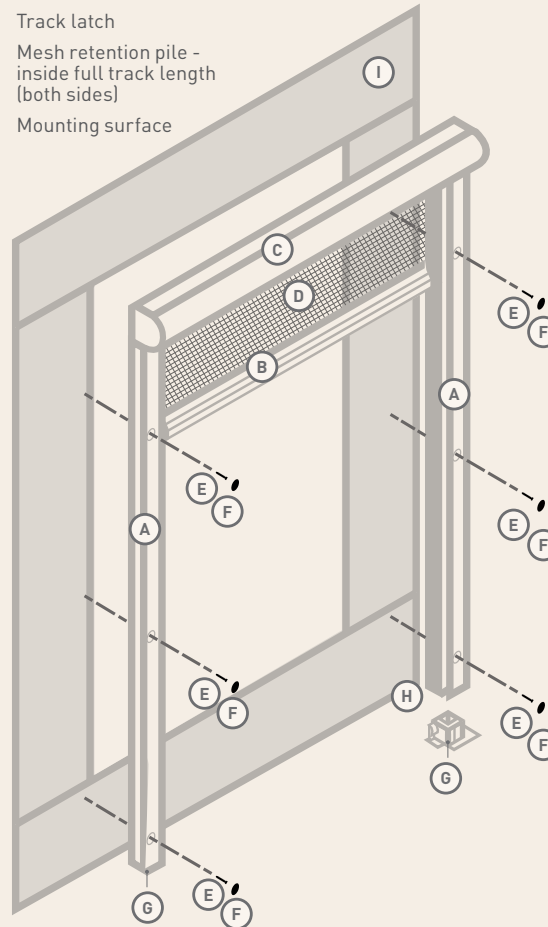

## IN-JAMB MOUNT

**SERENE DESIGN SPECIFICATIONS**  
(external assembled view)

### PARTS SPECS

- A** Aluminum track  
Standard version -  $57/64$ " W x  $1-3/8$ " H  
Narrow version -  $57/64$ " W x  $29/32$ " H
- B** Aluminum slidebar  $3/32$ " W x  $1-13/32$ " H
- C** Aluminum housing assembly  $2-19/64$ " W x  $2-7/64$ " H
- D** PVC coated fiberglass mesh
- E** Flathead screw #6 x  $3/4$ " (#5 head) - depending on mounting surface
- F** Track latch
- G** Mesh retention pile - inside full track length (both sides)
- H** Mounting surface

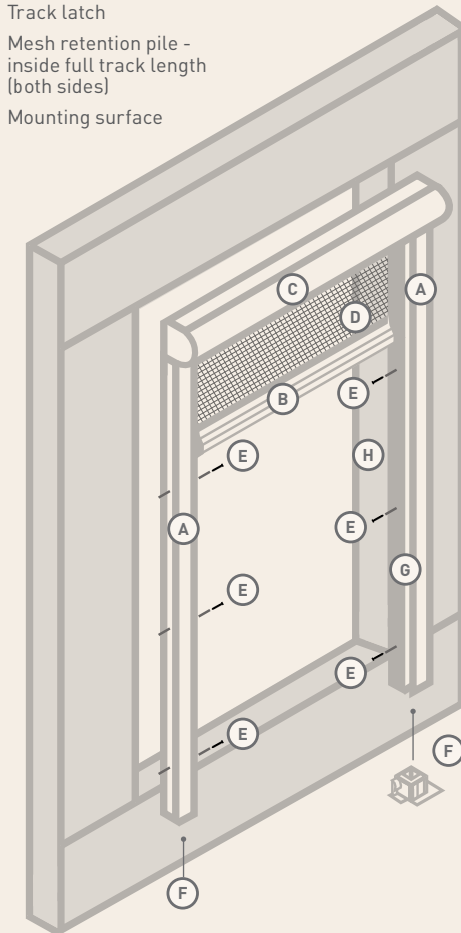



*The venerated retractable window screen  
for custom wood windows*

---

**FEATURES**

Wide range of veneered wood finishes

Built-in latch

Mesh retention system

Ergonomically designed handle

Optional removable tracks

Completely stainable

---

**BENEFITS**

Insect protection

Fresh air ventilation

Retracts out of sight

Unobstructed views

---

**INSTALLATION OPTIONS**

In-jamb mount



# Applications

Prestige screens are custom made and professionally installed to fit all window types.

- Single-hung**
- Double-hung**
- Sliding**
- Awning**

## Casement



# Customization

---

## FINISHES

### Wood Veneer

Choose from one of seven wood veneer options.



PINE



MAHOGANY



RED OAK



WALNUT



CHERRY



FIR



ALDER

### Completely Stainable

Prestige screens can be stained to match any wood grain finish, thereby allowing them to blend perfectly with your custom wood windows.

\* Please note that the appearance of the colors illustrated will differ from the actual coated samples or finished articles.

---

## MESH

Prestige screens feature BetterVue mesh which delivers insect protection with excellent visibility, making your view distinct and more vibrant.

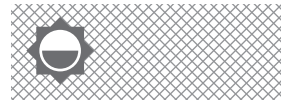

### STANDARD

Reduces up to 36% of UV rays



# Specifications

Prestige screens are custom made and professionally installed for any wood window application. Maximum sizes are determined by height and width ratios detailed in the chart below.

	WIDTH	HEIGHT
PRESTIGE	18" to 72"	Max 78"

FOR ILLUSTRATIVE PURPOSES ONLY  
NOT DRAWN TO SCALE

All components are color matched except mesh.

## IN-JAMB MOUNT ONLY

### PRESTIGE DESIGN SPECIFICATIONS (external assembled view)

#### PARTS SPECS

- A** Veneered aluminum track  
Fixed -  $\frac{7}{8}$ "W x  $1-\frac{11}{32}$ "H  
Removable -  $\frac{7}{8}$ "w x  $1-\frac{11}{32}$ "H
- B** Wooden slidebar  
 $1-\frac{1}{2}$ "W x  $1-\frac{13}{32}$ "H
- C** Veneered aluminum housing assembly  
 $1-\frac{29}{32}$ "W x  $2-\frac{1}{4}$ "H
- D** PVC coated fiberglass mesh
- E** Flathead screw #6 x  $\frac{3}{4}$ " (#5 head) - depending on mounting surface
- F** Track latch
- G** Mesh retention pile - inside full track length (both sides)

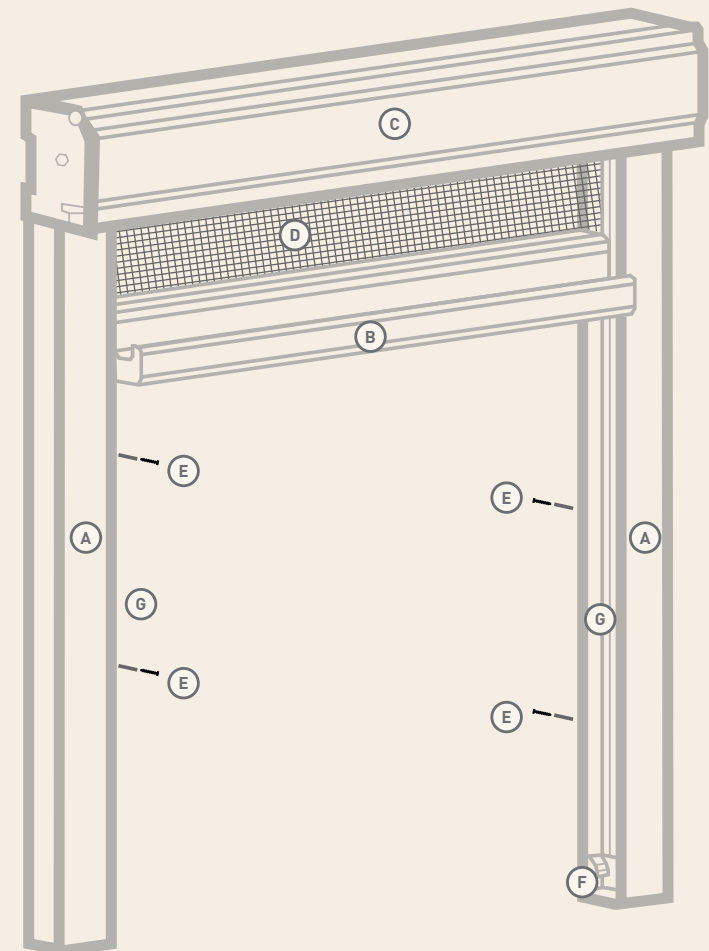



*There when you need us,  
enhancing your lifestyle,  
making us your choice for  
retractable screen solutions...  
experience Phantom.*





Your Phantom Screens Representative  
1.888.PHANTOM



**CORPORATE OFFICE**

Phantom Mfg. (Int'l) Ltd.  
30451 Simpson Road  
Abbotsford, BC  
V2T 6C7 Canada

TF: 1.888.444.4142  
Tel: 1.604.855.3654

phantom@phantomscreens.com  
**phantomscreens.com**

**USA MAIL**

P.O. Box 1907  
Sumas, WA  
98295-1907 USA

**CANADA MAIL**

P.O. Box 2310  
Abbotsford, BC  
V2T 4X2 Canada